

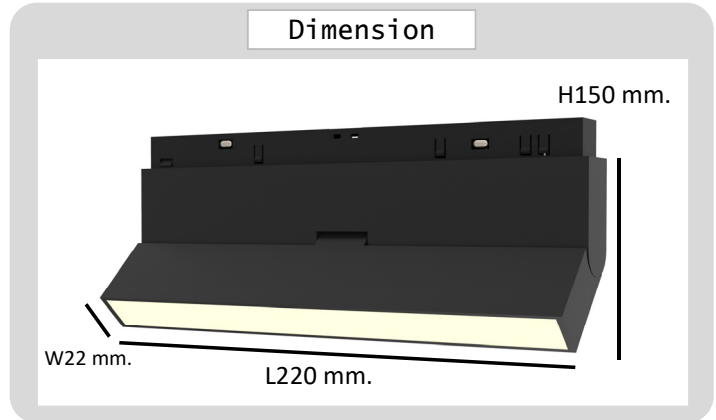

Project : \_\_\_\_\_  
Approve : \_\_\_\_\_

## Product Specification

### Product

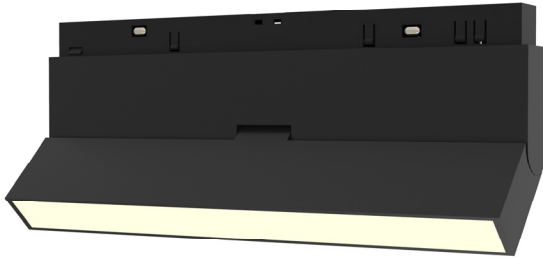

### Specification

PRODUCT CODE	:	MG-321-C20Z220F
NAME	:	MAGNETIC TRACK LIGHT
BRAND	:	ARTISAN LIGHTING PHUKET
MATERIAL	:	DIE-CAST ALUMINUM
FINISHING	:	SAND BLACK
INPUT VOLTAGE	:	DC 48V
LAMP TYPE	:	LED BUILD IN CREE
POWER	:	12W
CCT	:	2700K,3000K, 4000K
BEAM ANGLE	:	120D
CRI RATING	:	CRI 90
DIMENSION	:	L220*W22*H150 mm.
ADJUSTABLE	:	Yes
DIMMABLE	:	NO, 0-10V, DALI, OPTIONAL
REMARK	:	

## Artisan Lighting Phuket Co., Ltd.

100/364-5 Moo.5 Pracha-U-Thid Rd., Rassada, Muang, Phuket 83000 Thailand. Tel : (+66) 076 376 101  
Mobile & Line ID : 086 945 8988, 093 579 9471, Email : support@artisanlighting.net, www.artisanlighting.net