



Project : _____

Approve : _____

**Product
Specification**

Product

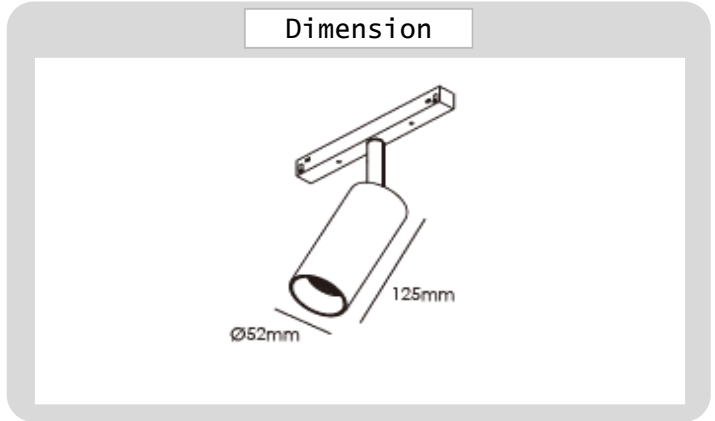

CREE LEDs

Specification

PRODUCT CODE	:	MG-321-C20S02015W
NAME	:	MAGNETIC TRACK LIGHT
BRAND	:	ARTISAN LIGHTING PHUKET
MATERIAL	:	DIE-CAST ALUMINUM+PC
ADJUSTABLE	:	YES
FINISHING	:	SAND BLACK
INPUT VOLTAGE	:	DC 48V
LAMP TYPE	:	LED BUILD IN CREE
POWER	:	15W
CCT	:	2700K,3000k, 4000K
BEAM ANGLE	:	10D 15D 24D 36D 50D
CRI RATING	:	CRI 90
DIMMABLE	:	NO, YES, 0-10V, DALI
ACCESSORIES	:	HONEY COMP
LUMEN	:	900LM
DIMENSION	:	15W (D52x125 mm.)
REMARK	:	

Artisan Lighting Phuket Co., Ltd.

100/364-5 Moo.5 Pracha-U-Thid Rd., Rassada, Muang, Phuket 83000 Thailand. Tel : (+66) 076 376 101
Mobile & Line ID : 086 945 8988, 093 579 9471, Email : support@artisanlighting.net, www.artisanlighting.net