

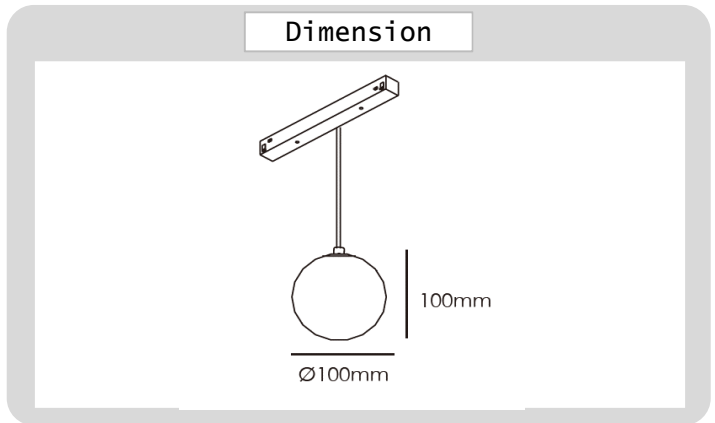

Project : \_\_\_\_\_  
Approve : \_\_\_\_\_

**Product  
Specification**

## Product



## Specification

PRODUCT CODE	:	MG-321-C20QD005
NAME	:	MAGNETIC TRACK LIGHT
BRAND	:	ARTISAN LIGHTING PHUKET
MATERIAL	:	DIE-CAST ALUMINUM+PC
ADJUSTABLE	:	NO
FINISHING	:	SAND BLACK
INPUT VOLTAGE	:	DC 48V
LAMP TYPE	:	LED BUILD IN CREE
POWER	:	5W
CCT	:	2700K,3000k, 4000K
BEAM ANGLE	:	350D
CRI RATING	:	CRI 90
DIMMABLE	:	NO, YES,0-10V, DALI ,OPTIONAL
LUMEN	:	564Lm
DIMENSION	:	D100x100 mm.
REMARK	:	

**Artisan Lighting Phuket Co., Ltd.**

100/364-5 Moo.5 Pracha-U-Thid Rd., Rassada, Muang, Phuket 83000 Thailand. Tel : (+66) 076 376 101  
Mobile & Line ID : 086 945 8988, 093 579 9471, Email : support@artisanlighting.net, www.artisanlighting.net