

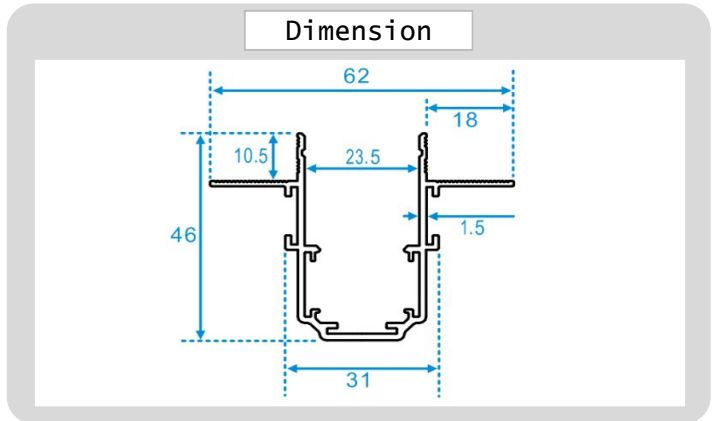

Project : \_\_\_\_\_  
Approve : \_\_\_\_\_

## Product Specification

### Product



### Specification

PRODUCT CODE	: MG-321-XS20
NAME	: RECESSED MOUNTED MAGNETIC TRACK LIGHT
BRAND	: ARTISAN LIGHTING PHUKET
MATERIAL	: ALUMINUM FLAT RED COPPER
FINISHING	: BLACK
INPUT VOLTAGE	: 220V,48V,24V
DIMENSION	: W46xH62xL1000, L2000, L3000 mm.
REMARK	:

Artisan Lighting Phuket Co., Ltd.

100/364-5 Moo.5 Pracha-U-Thid Rd., Rassada, Muang, Phuket 83000 Thailand. Tel : (+66) 076 376 101  
Mobile & Line ID : 086 945 8988, 093 579 9471, Email : support@artisanlighting.net, www.artisanlighting.net