

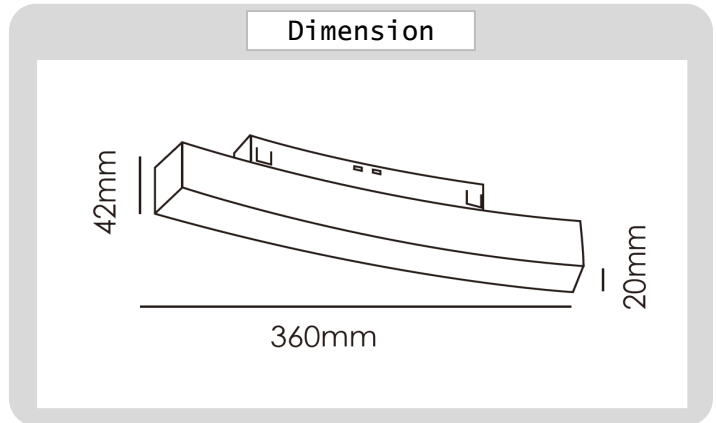

Project : _____
Approve : _____

**Product
Specification**

Product



Specification

PRODUCT CODE	:	MG-321-C20YF360
NAME	:	MAGNETIC TRACK LIGHT
BRAND	:	ARTISAN LIGHTING PHUKET
MATERIAL	:	DIE-CAST ALUMINUM
FINISHING	:	SAND BLACK
INPUT VOLTAGE	:	DC 48V
LAMP TYPE	:	LED BUILD IN BRIDGLUX
POWER	:	15W
CCT	:	2700K,3000k, 4000K
BEAM ANGLE	:	100D
CRI RATING	:	CRI 90
LUMEN	:	725Lm
DIMENSION	:	42x360x20 mm.
DIMMABLE	:	NO, 0-10V, DALI, OPTIONAL
REMARK	:	

Artisan Lighting Phuket Co., Ltd.

100/364-5 Moo.5 Pracha-U-Thid Rd., Rassada, Muang, Phuket 83000 Thailand. Tel : (+66) 076 376 101
Mobile & Line ID : 086 945 8988, 093 579 9471, Email : support@artisanlighting.net, www.artisanlighting.net